

BMHOLLY

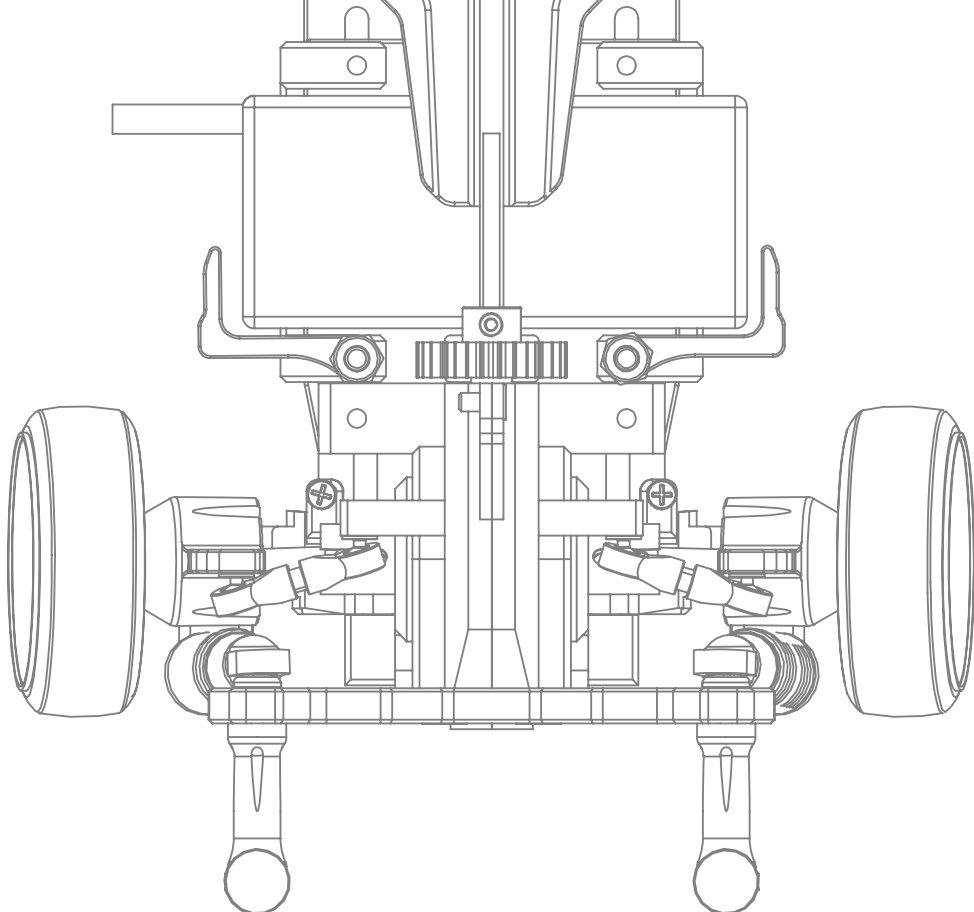



M2*2 Set Screw x 2



Rod End Adaptor x 2



M2*4 CS Screw x 2



M2*5 RH Screw x 2



1.6*3*0.5 Spacer x 4



1.6*3*1 Spacer x 4



9.6mm Ball End Cap x 2



1.6*13 pin x 2

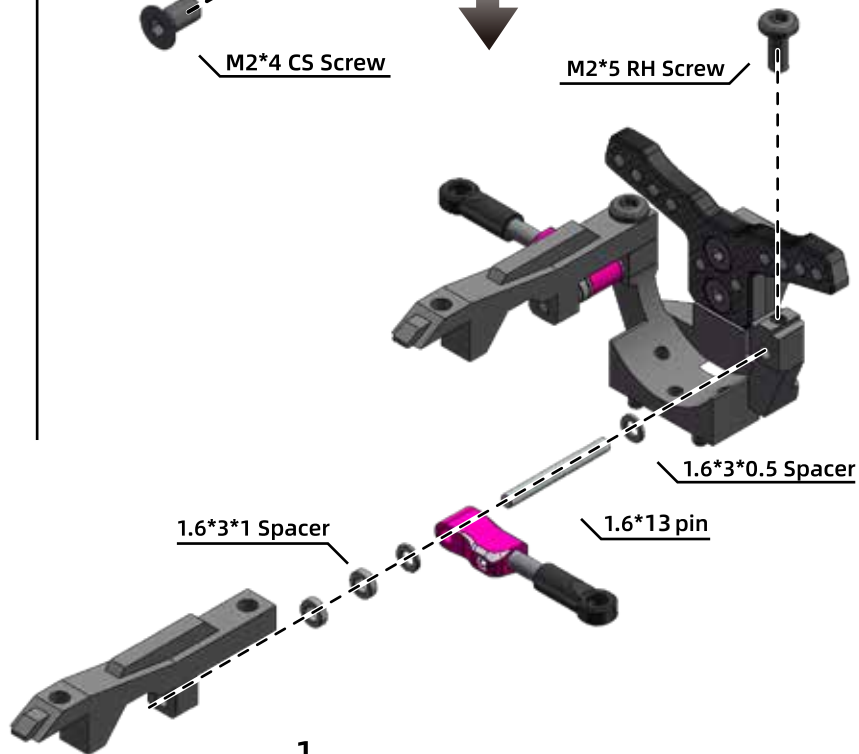
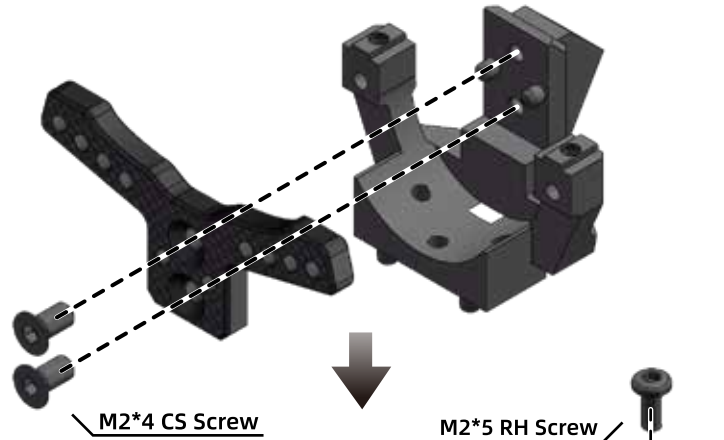
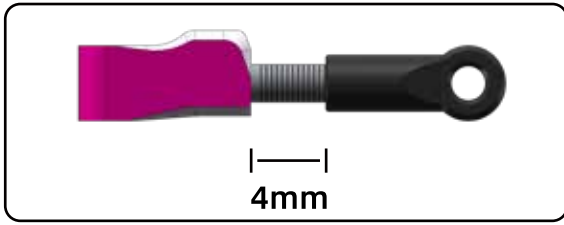
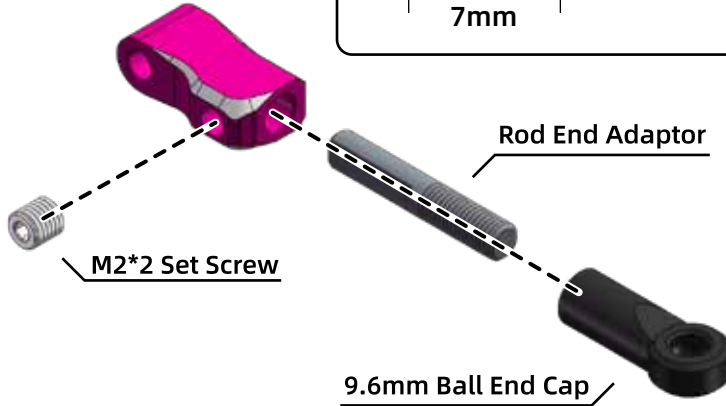
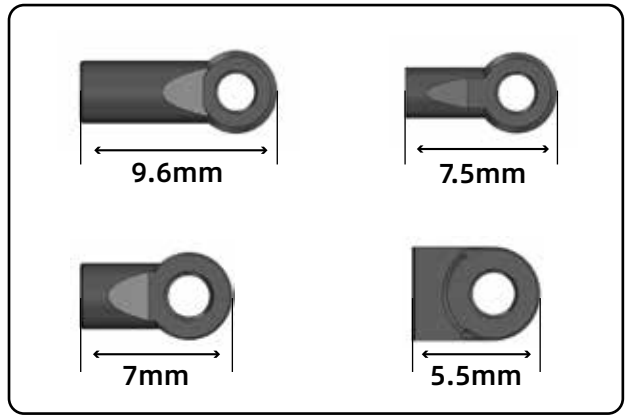

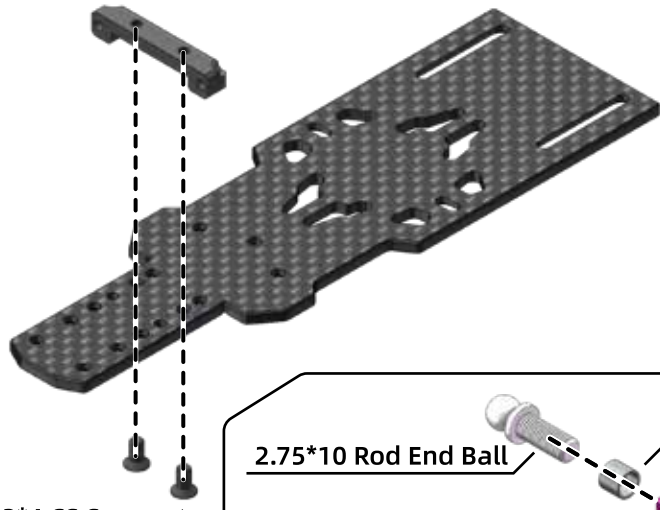

M2*4 CS Screw

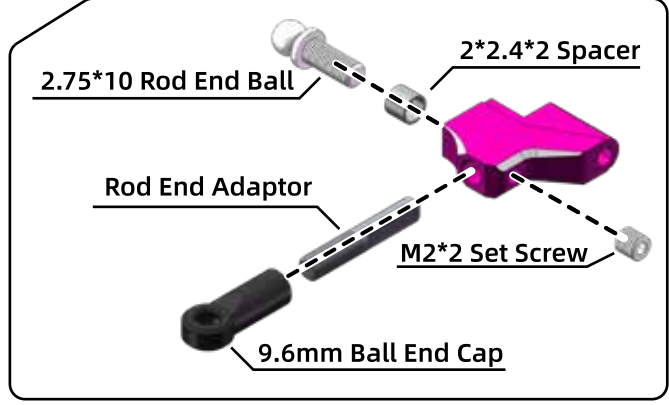









2.75*10 Rod End Ball

2*2.4*2 Spacer

Rod End Adaptor

M2*2 Set Screw

9.6mm Ball End Cap

-  M2*2 Set Screw x 2
-  M2*4 CS Screw x 4
-  1.6*3*1 Spacer x 4
-  1.6*13 pin x 2
-  2.75*10 Rod End Ball x 2
-  2*2.4*2 Spacer x 2
-  Rod End Adaptor x 2
-  9.6mm Ball End Cap x 2

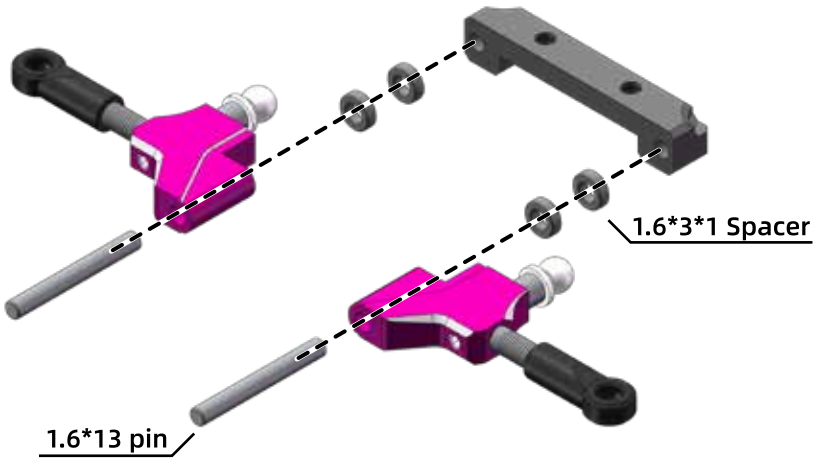

1.6*3*1 Spacer

1.6*13 pin

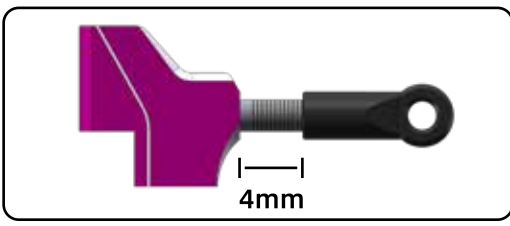

4mm

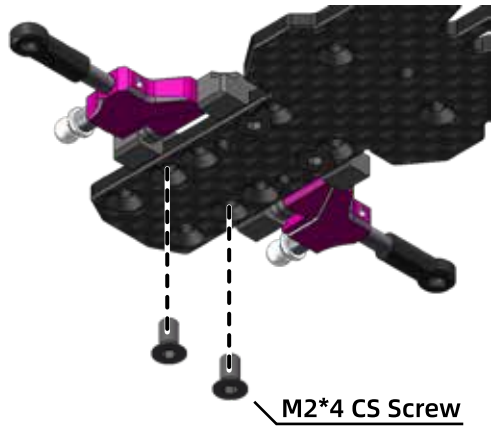

M2*4 CS Screw

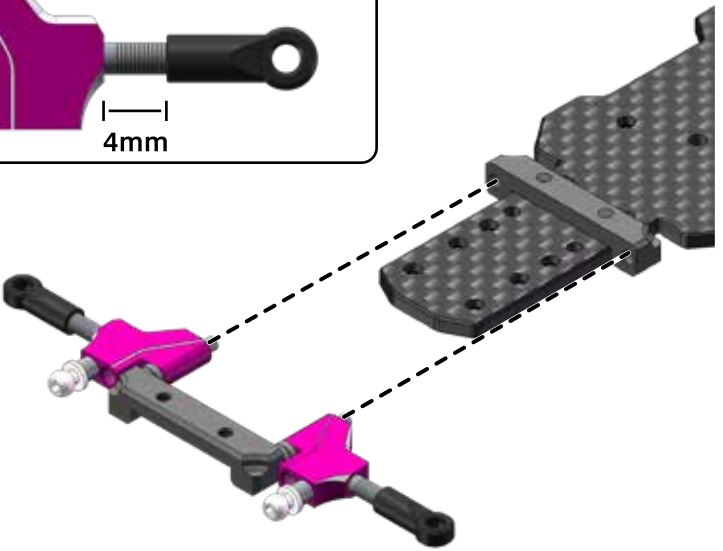



M1.6*4 CS Screw x 2



M1.6*3 CS Screw x 2



1.5*2.5*0.5 Spacer x 2



Suspension Pin Balls x 4









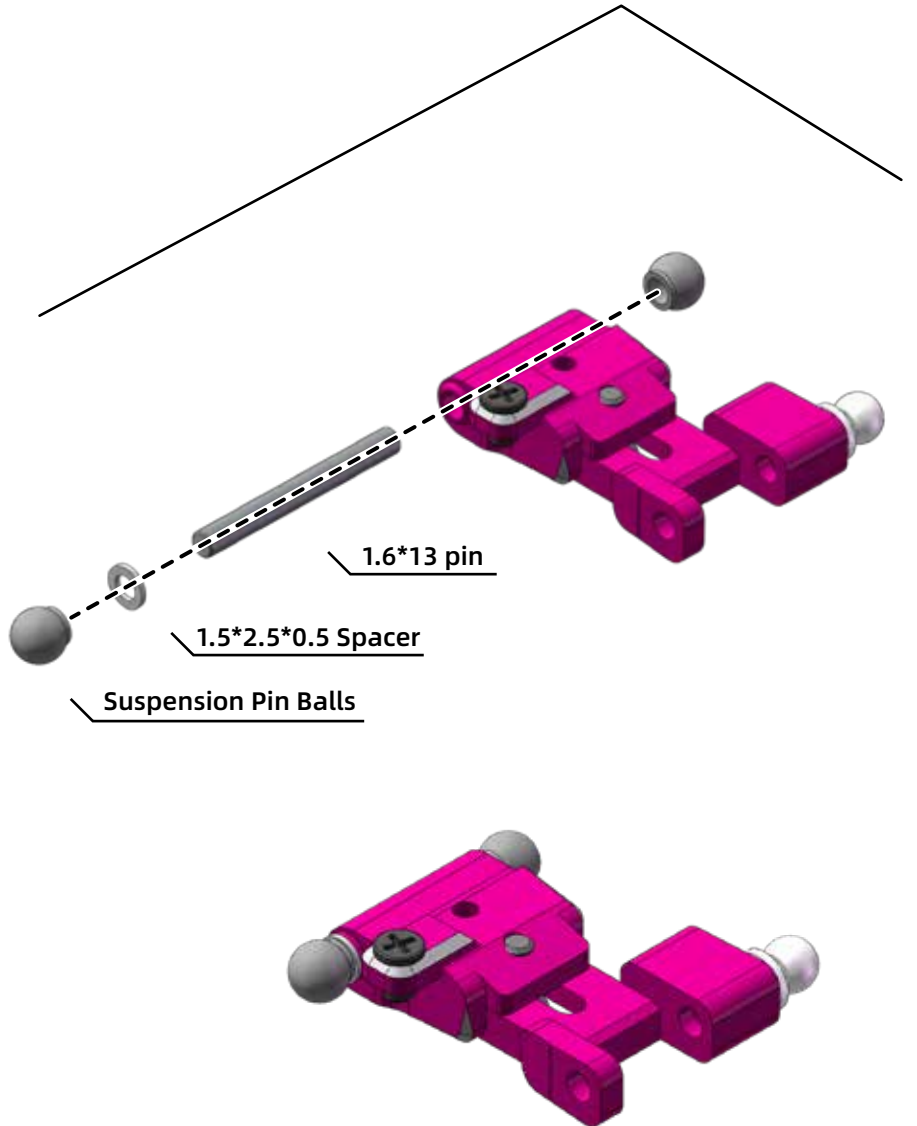
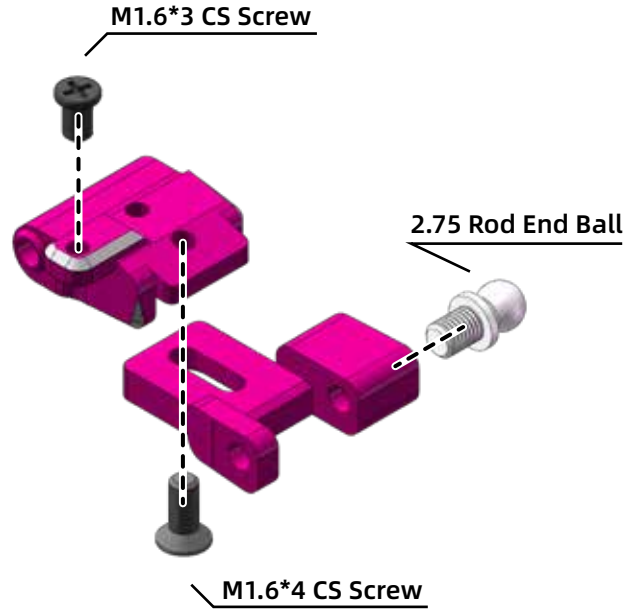

2.75 Rod End Ball x 2



1.6*13 pin x 2



-  2*5*2.5 Bearing x 2
-  2*5*2.5 Bearing x 1
-  6*10*2.5 Bearing x 2
-  2*14 pin x 1
-  M2*4 CS Screw x 2
-  M2*10 CS Screw x 1
-  M1.6*4 CS Screw x 1
-  13T Gear x 1

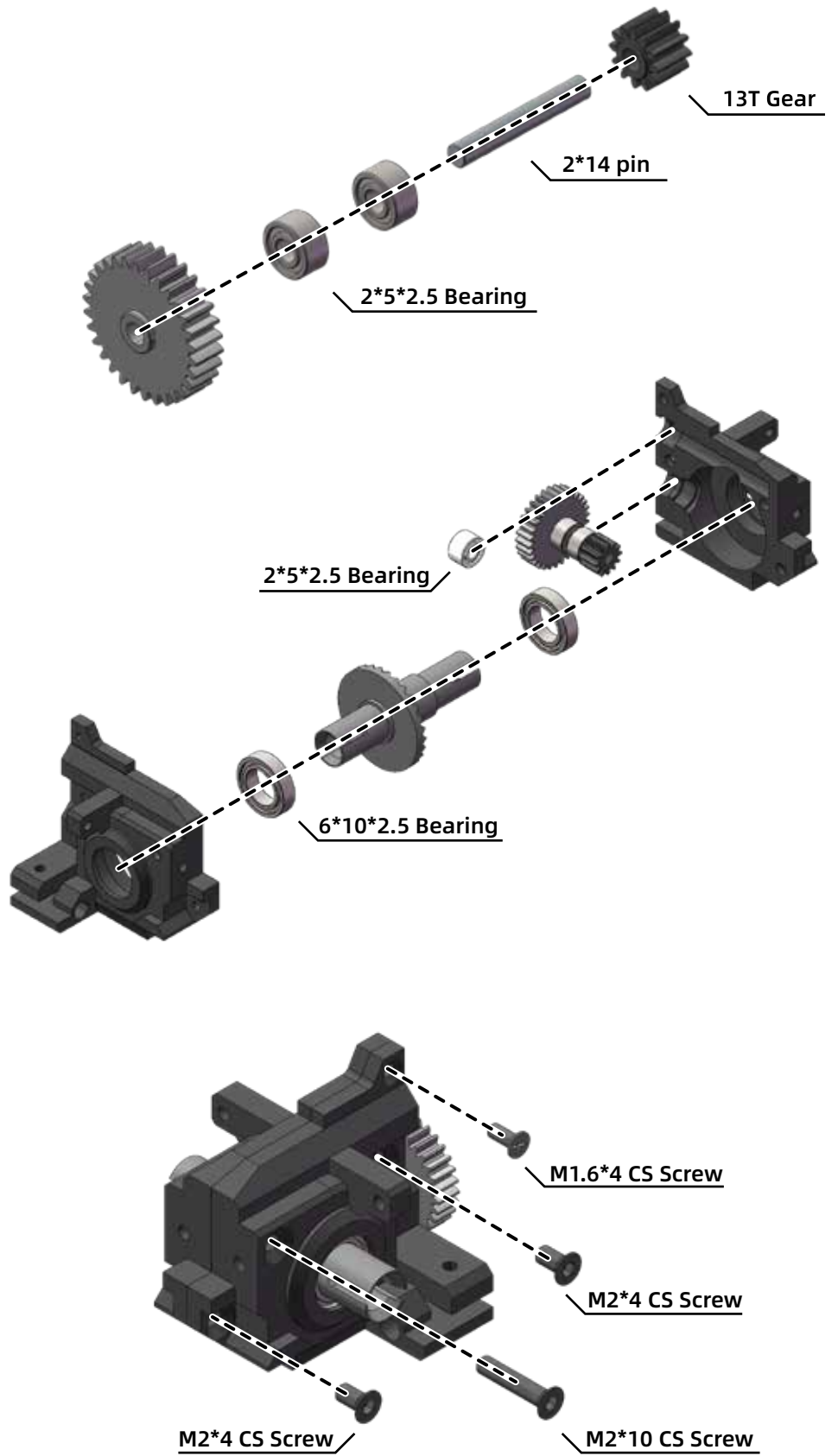

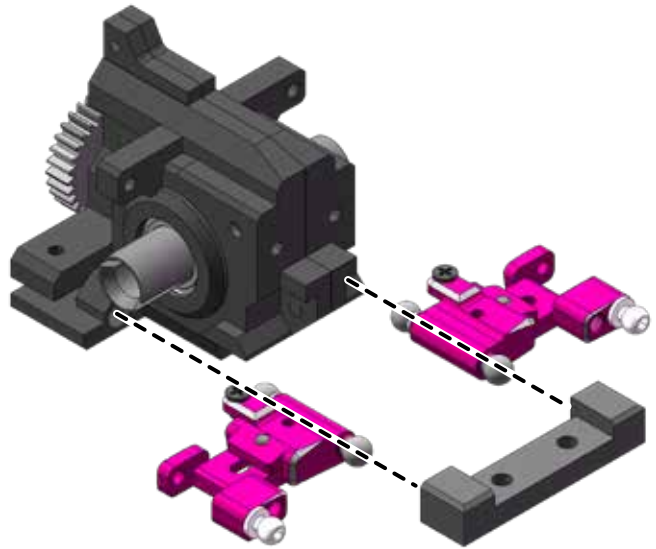

M2*6 CS Screw x 2



2.5 Rod End Ball x 2

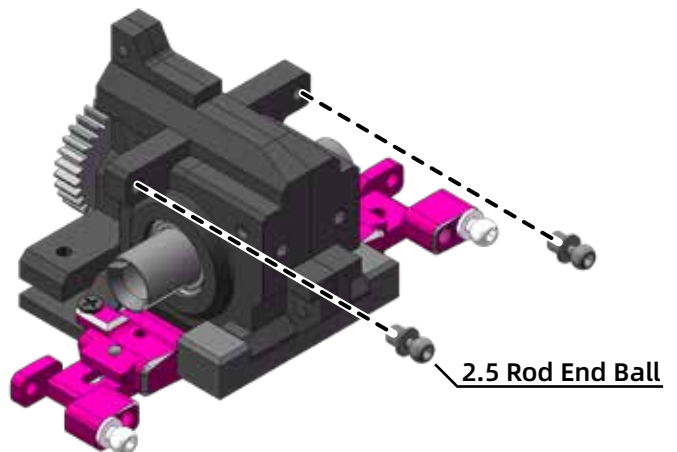
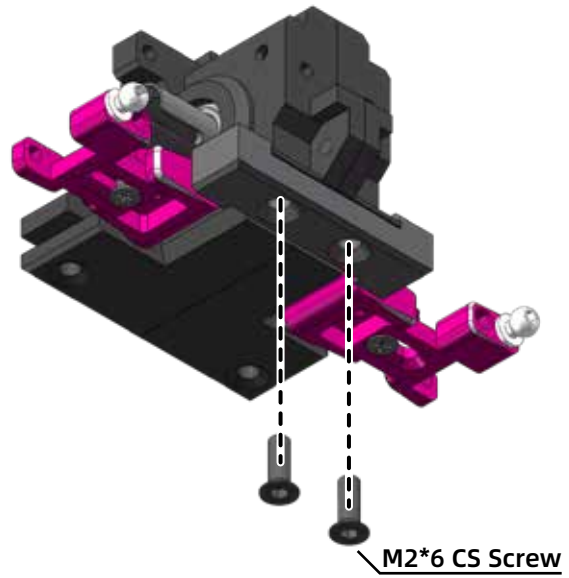



M1.6*3 CS Screw x 2



5*8*2.5 Bearing x 2



3*6*2.5 Bearing x 2



2.5 Rod End Ball x 2



1.6*10 pin x 2



5*8*0.2 Spacer x 2

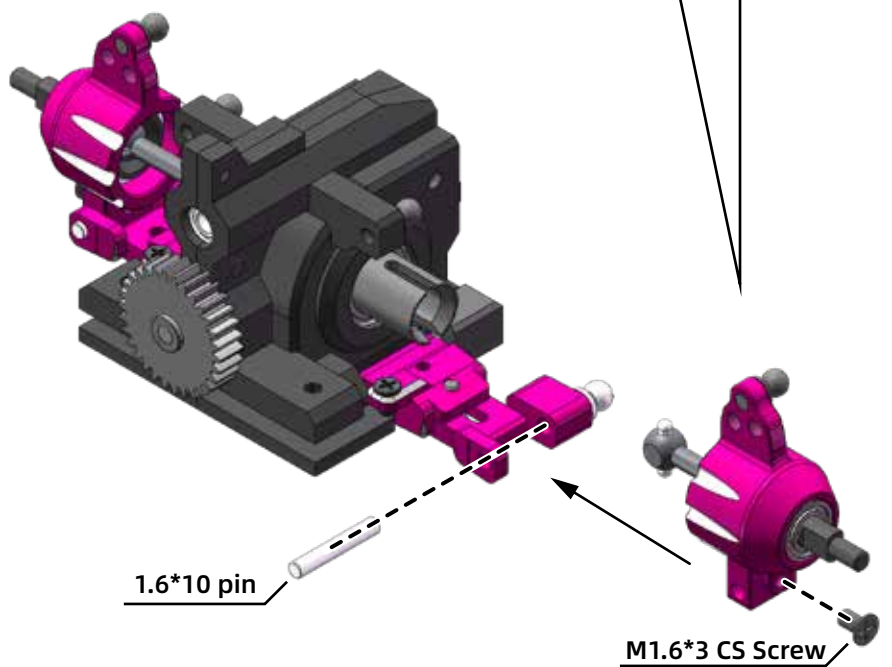
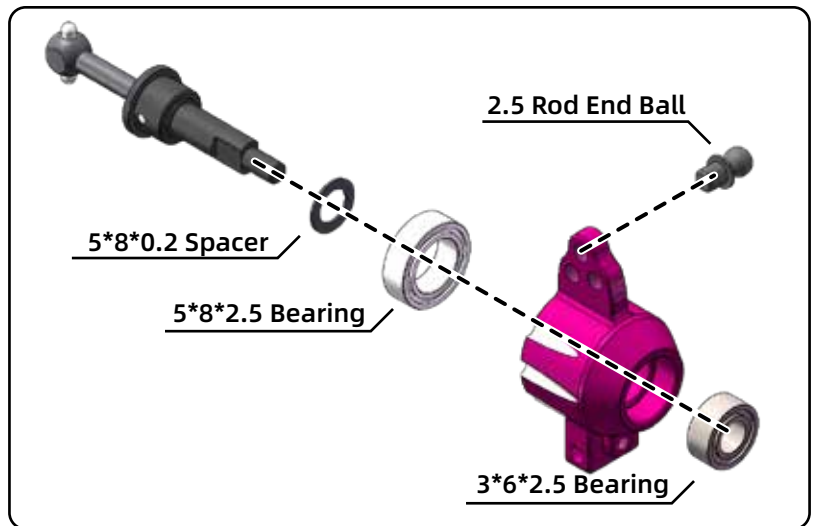
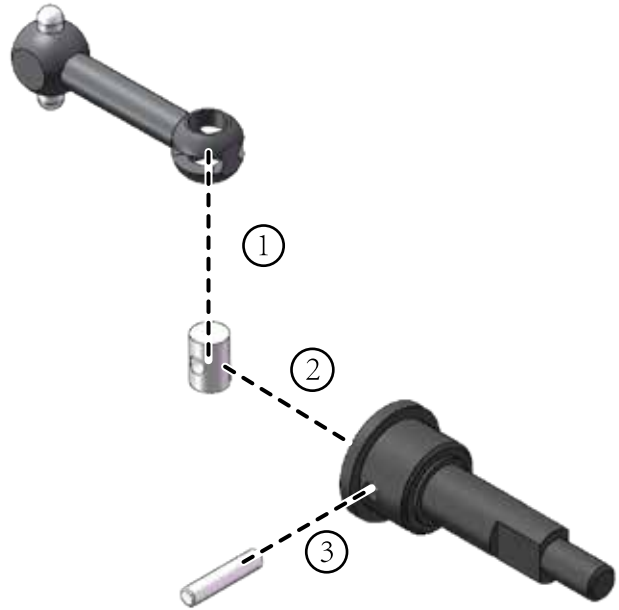



M2*5 RH Screw x 3



2.5 Rod End Ball x 3



2*2.4*2.2 Spacer x 4



M2*L8 x 1



M2*5 RH Screw

②

2*2.4*2.2 Spacer

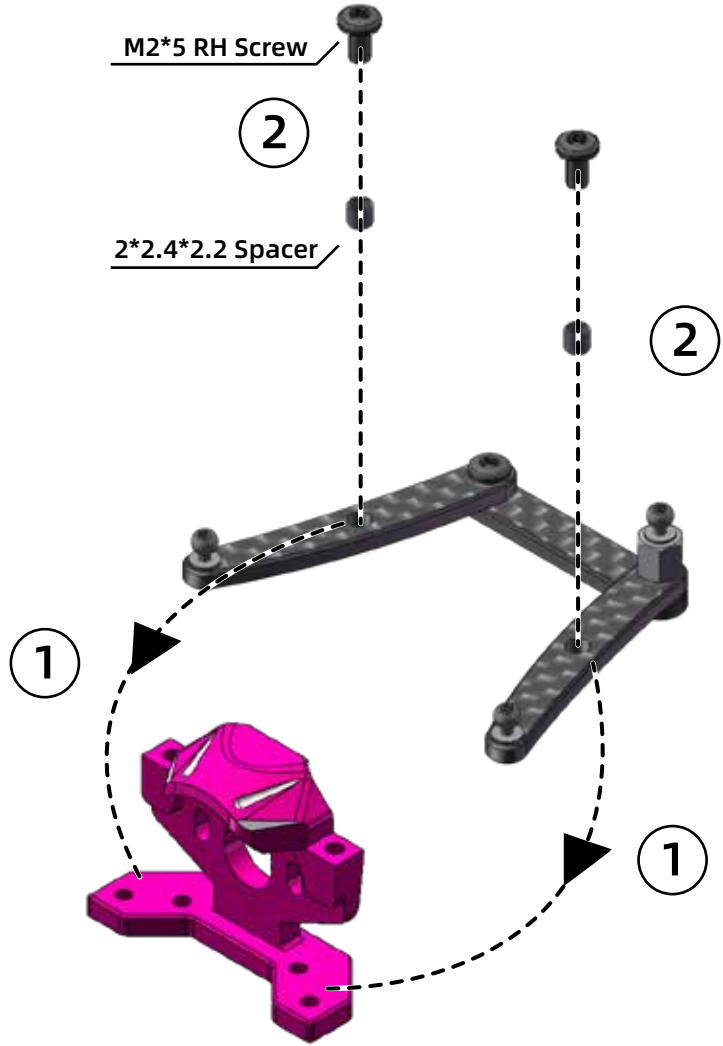

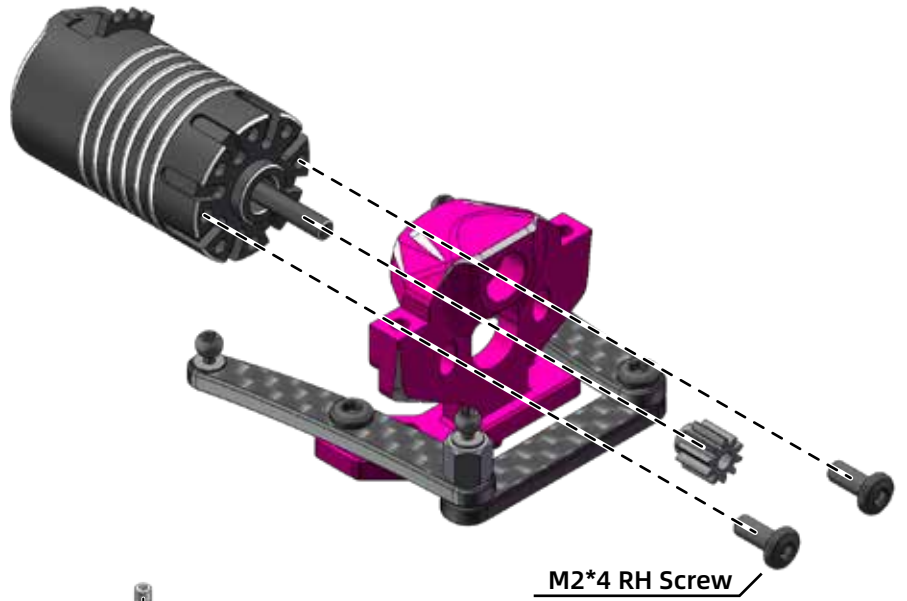

M2*2 Set Screw x 1



M2*4 RH Screw x 2

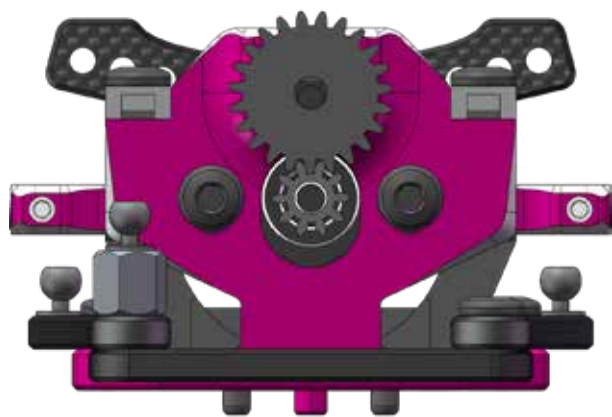
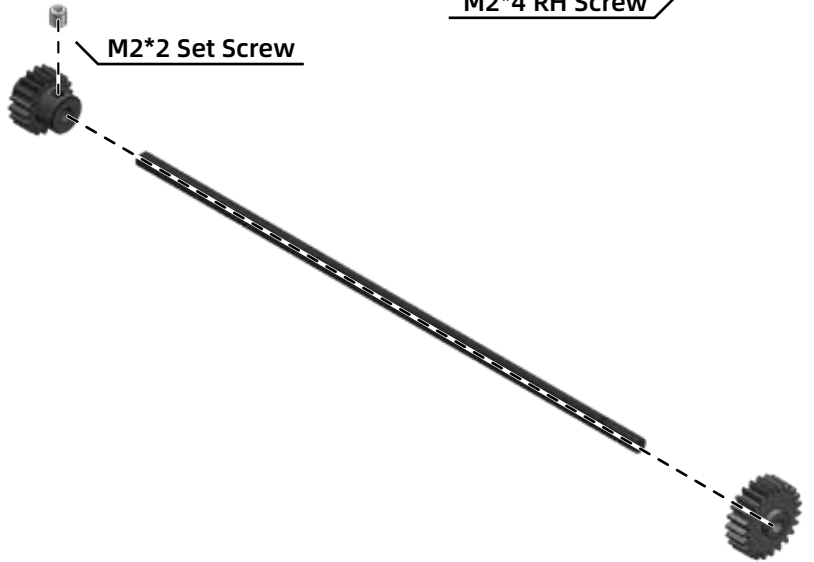

Make sure the gap between the spur and pinion are correct.

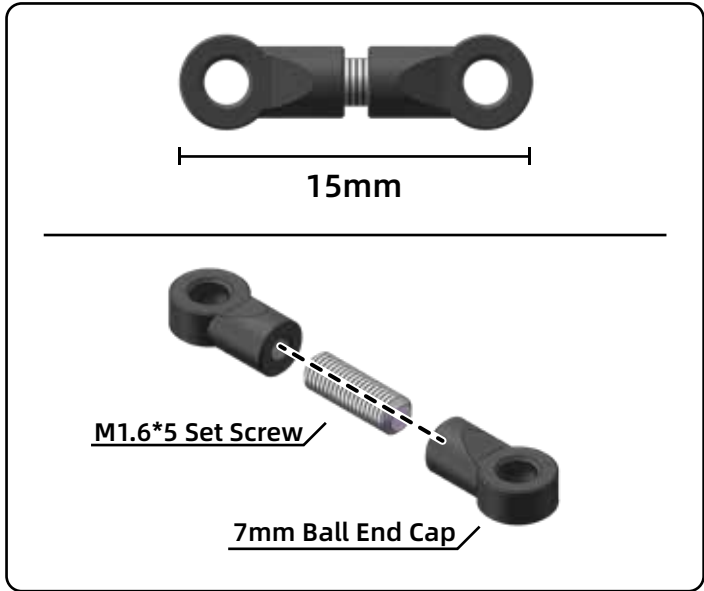

 M1.6*2 Set Screw x 2

 7mm Ball End Cap x 4

 M2*5 RH Screw x 2

 2.75 Rod End Ball x 2

 M1.6*5 Set Screw x 2

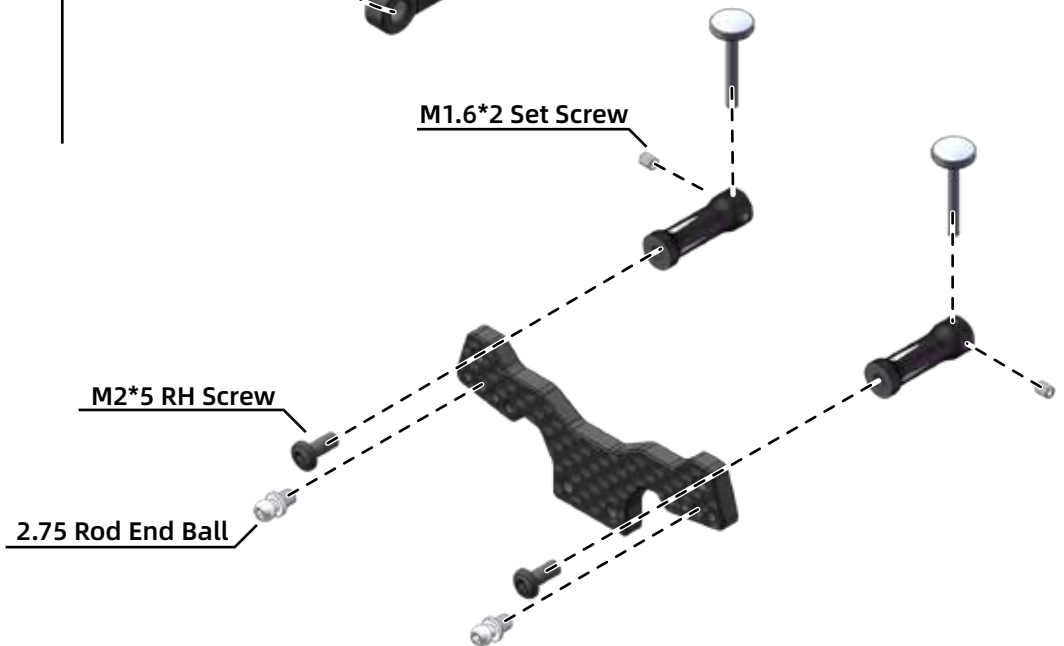
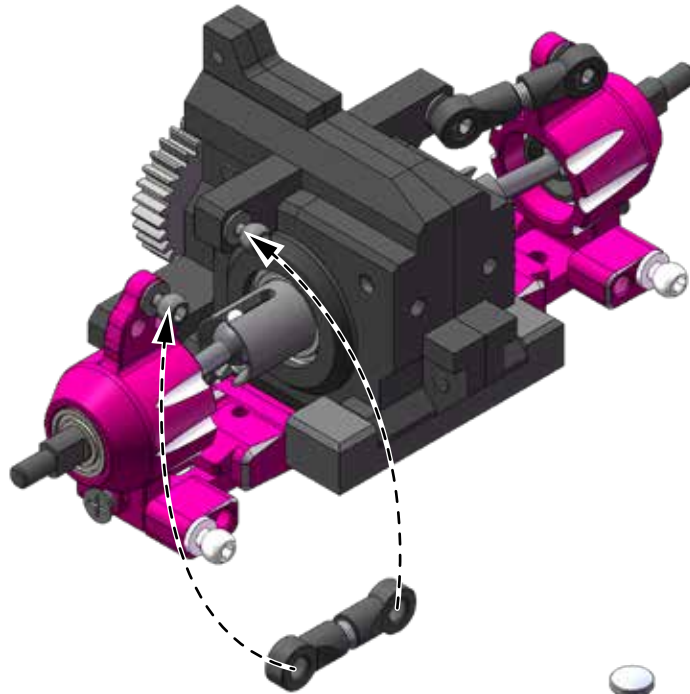



Long Shock x 2



Long Body x 2



Adjusting Nut x 2



Soft Spring x 2



M2*6 CS Screw x 2

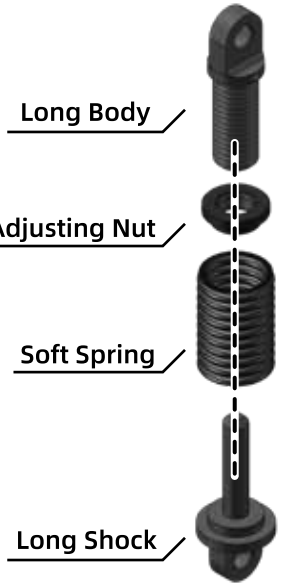

Long Body

Adjusting Nut

Soft Spring

Long Shock

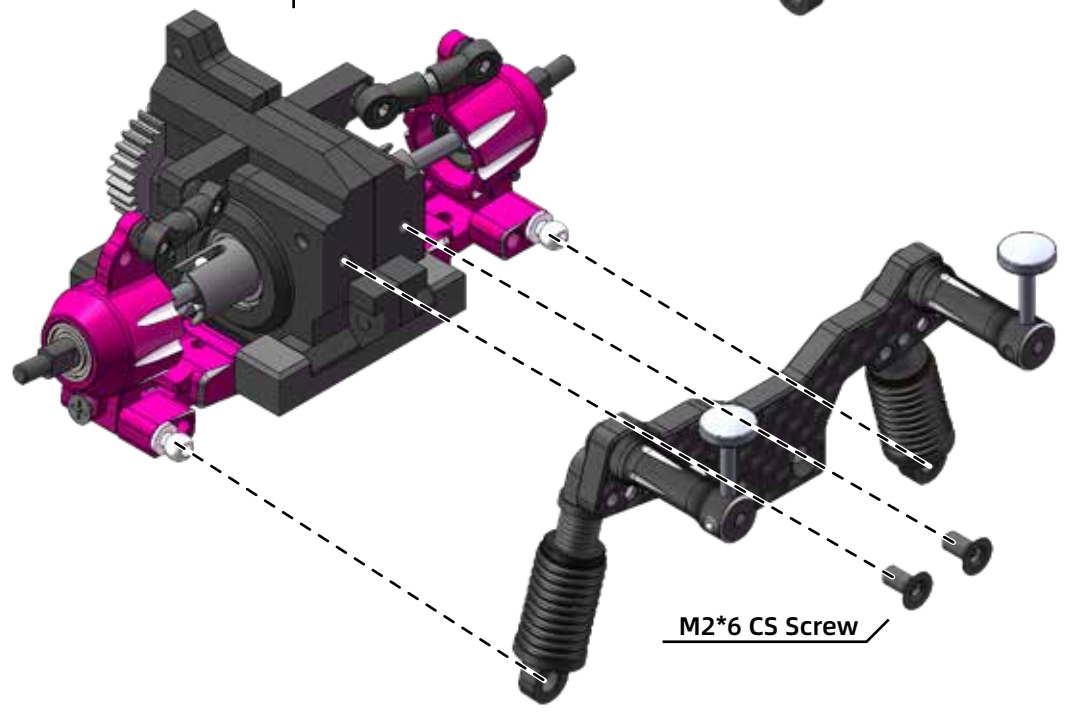

M2*6 CS Screw

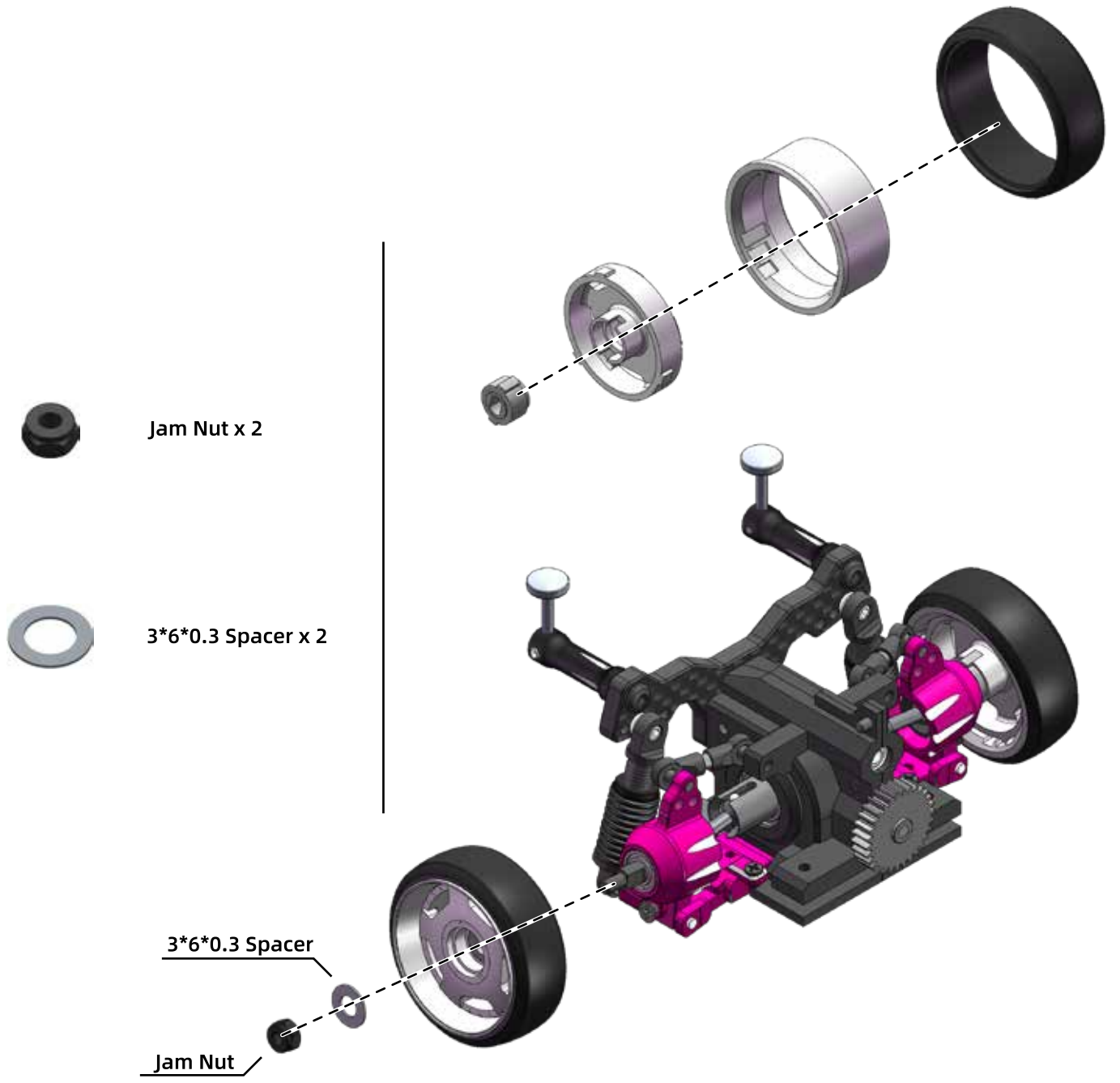



M2*4 CS Screw x 6



M2*4 RH Screw x 2



2.5 Rod End Ball x 3

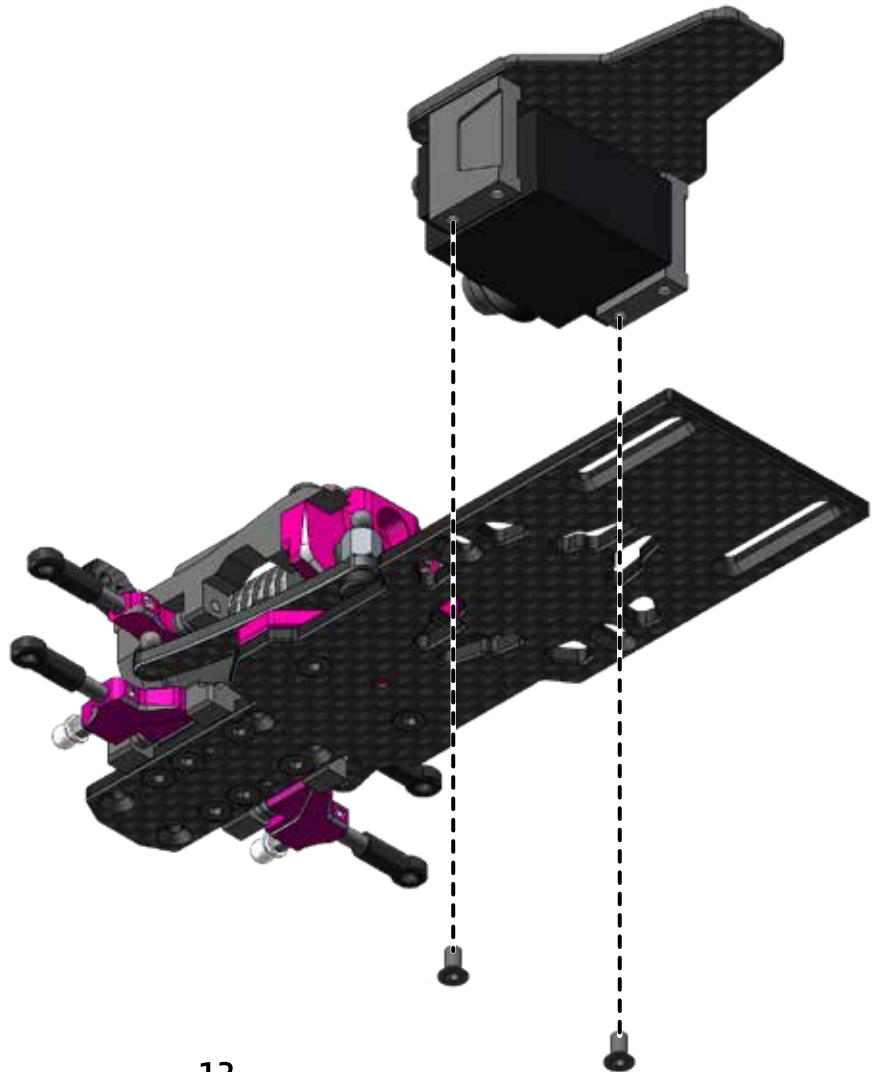
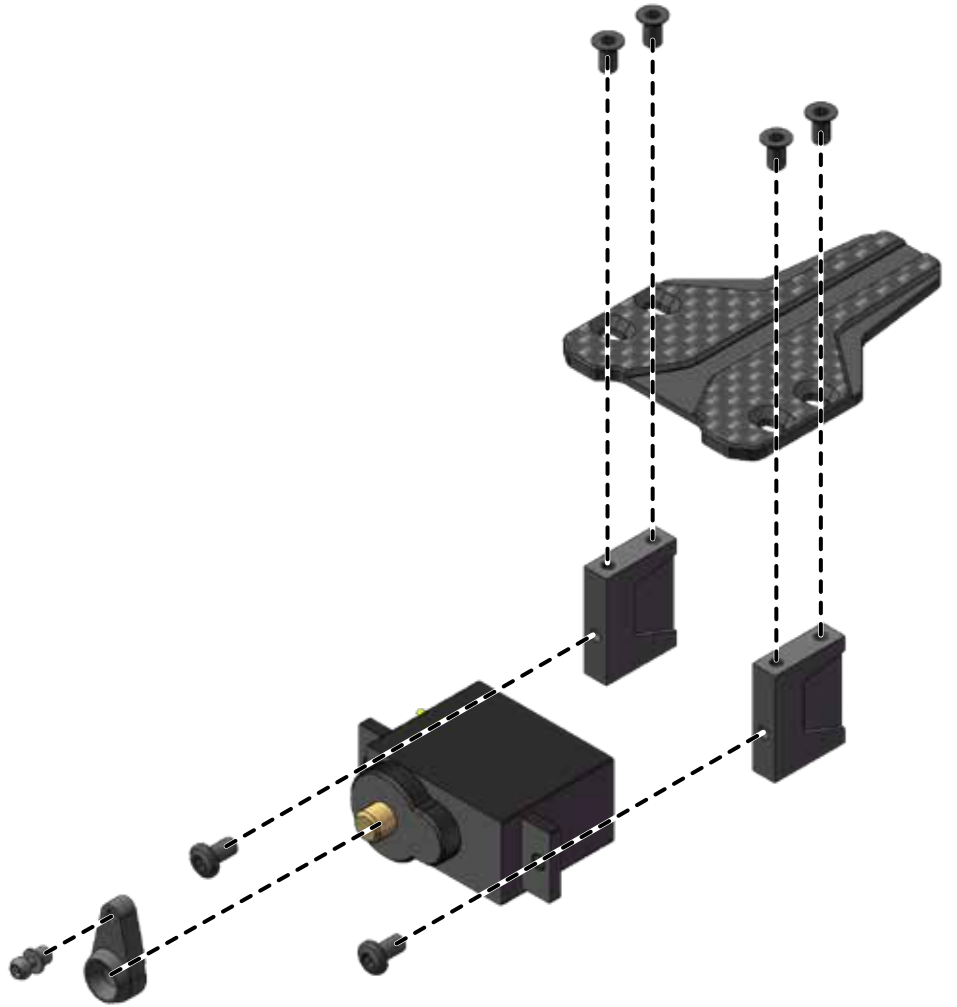

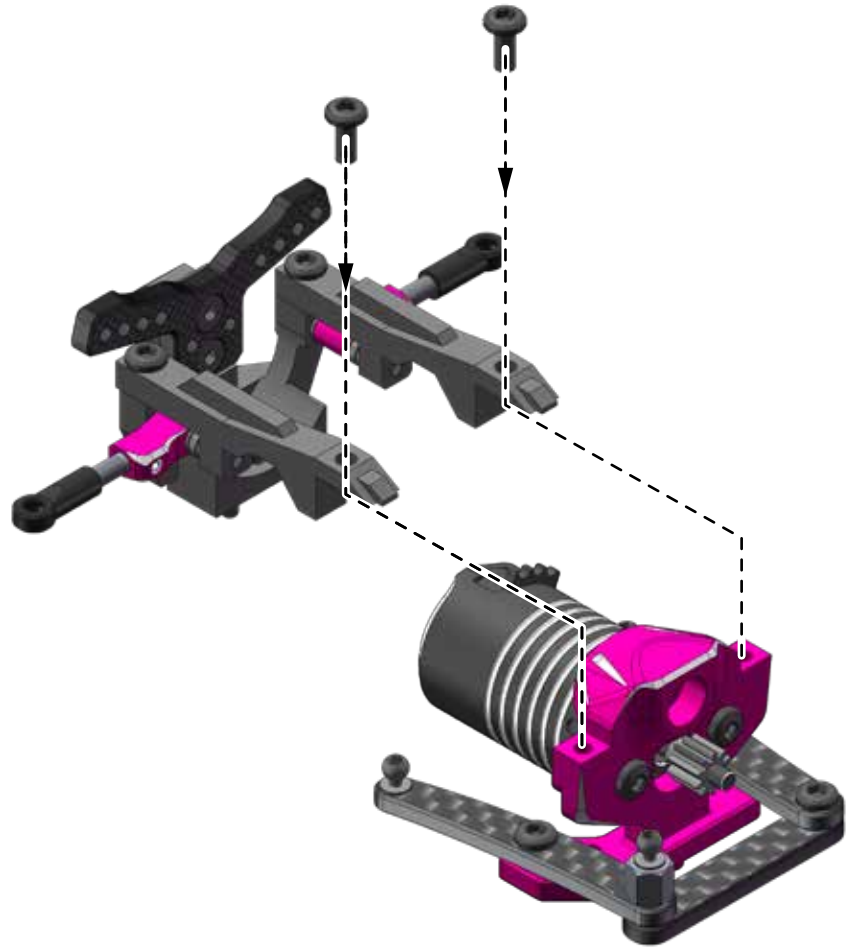

M2*5 RH Screw x 2



M2*4 CS Screw x 4

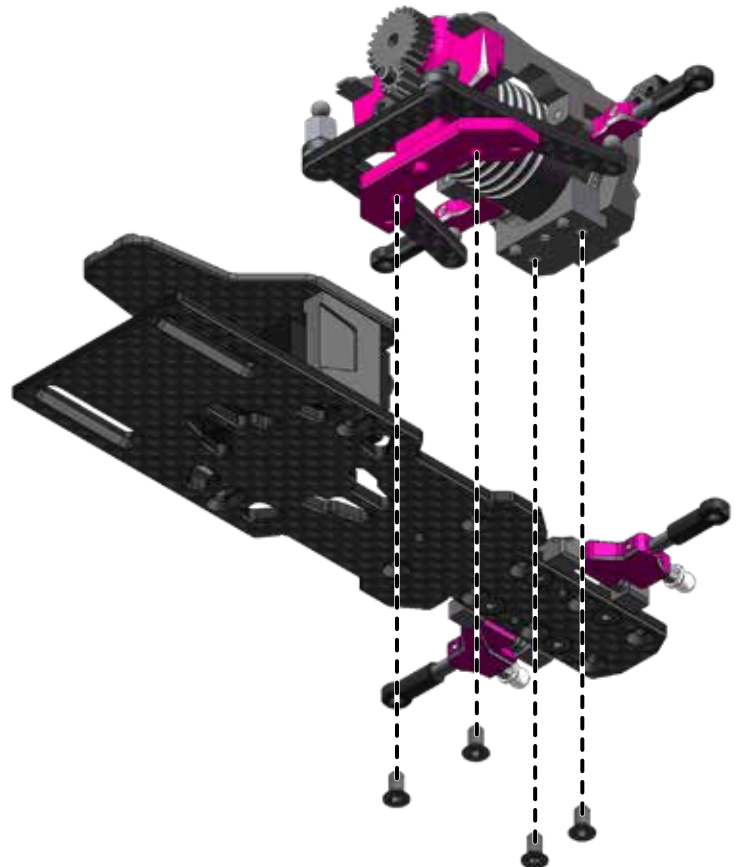



7.5mm Ball End Cap x 2



5.5mm Ball End Cap x 2



M1.6*10 Set Screw x 2

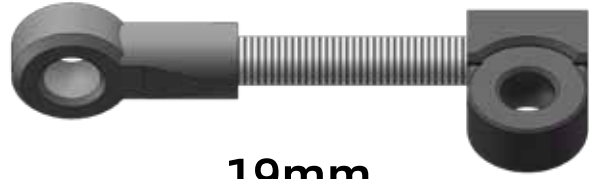

19mm

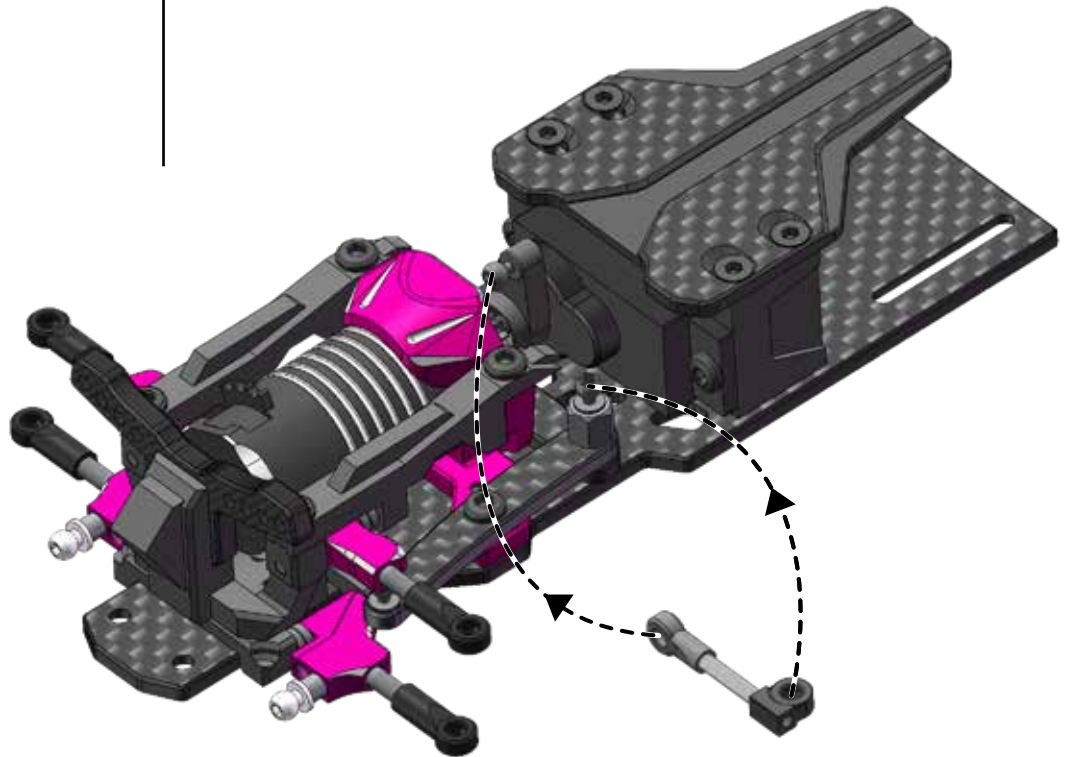
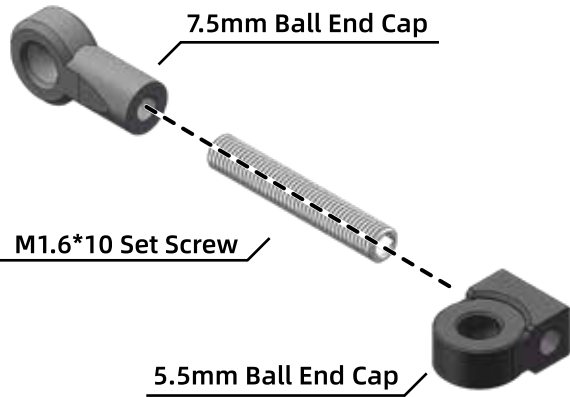



2.5 Rod End Ball x 6



3*6*2.5 Bearing x 4



Jam Nut x 2

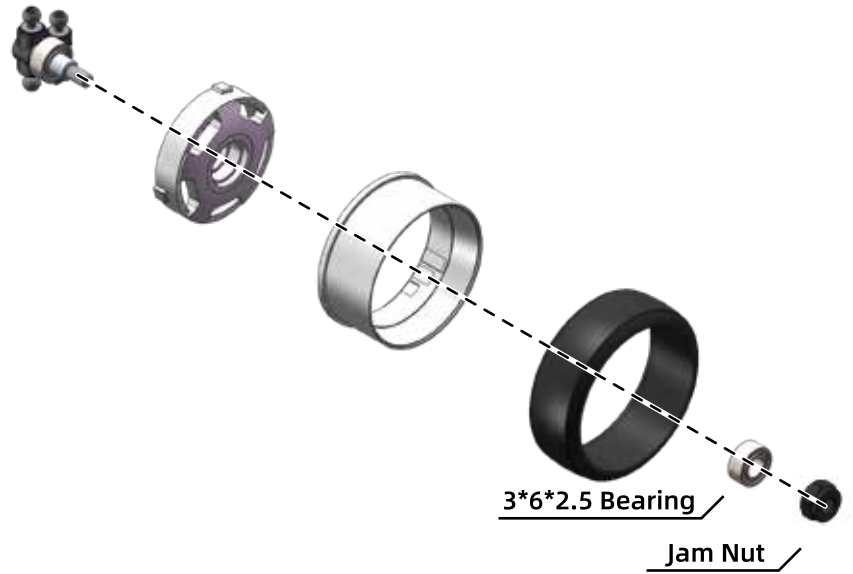
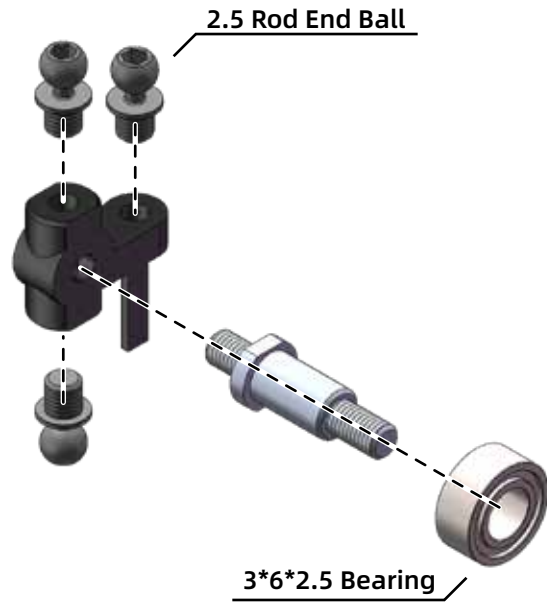



7.5mm Ball End Cap x 2



5.5mm Ball End Cap x 2



10mm Turn Buckle x 2

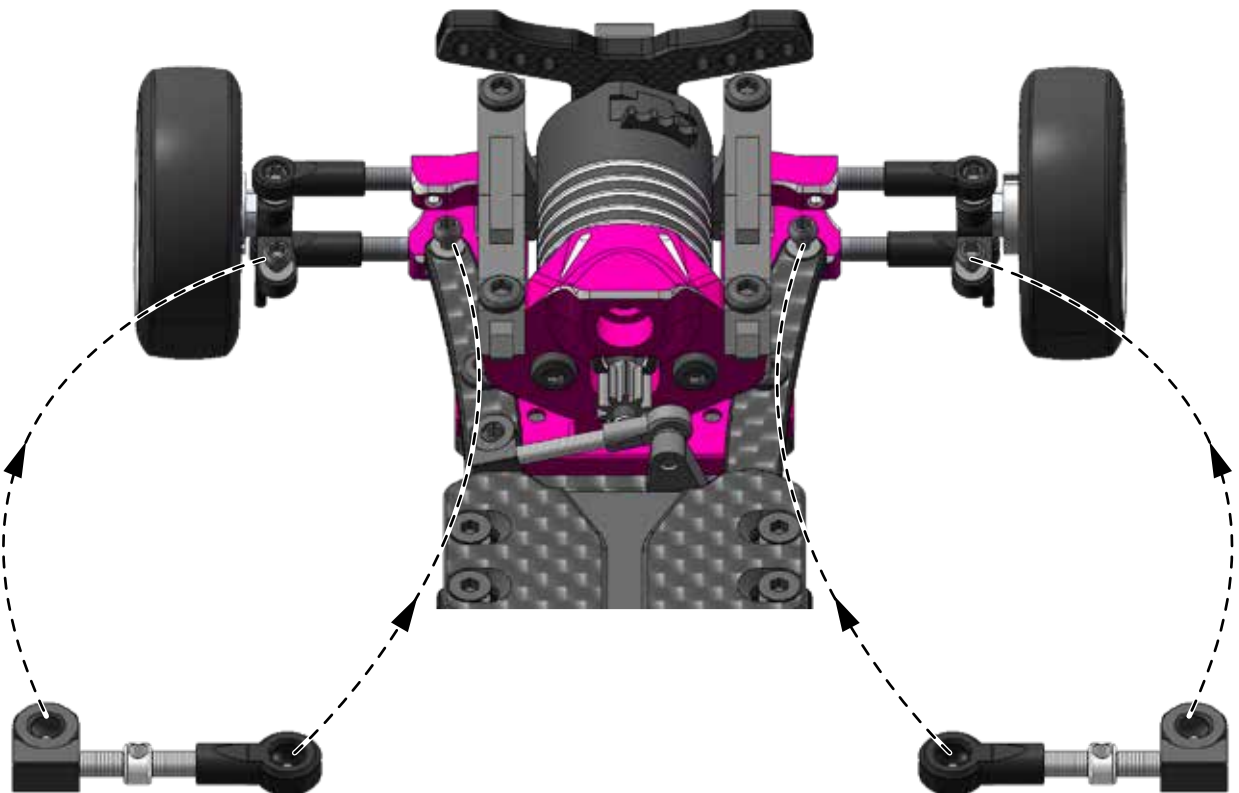
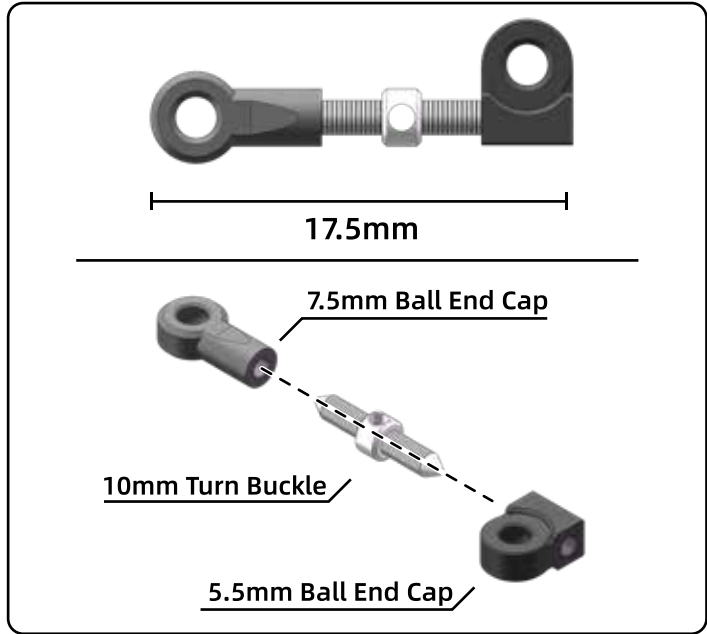



2.75 Rod End Ball x 2



Long Shock x 2



Long Body x 2



Adjusting Nut x 2



Hard Spring x 2

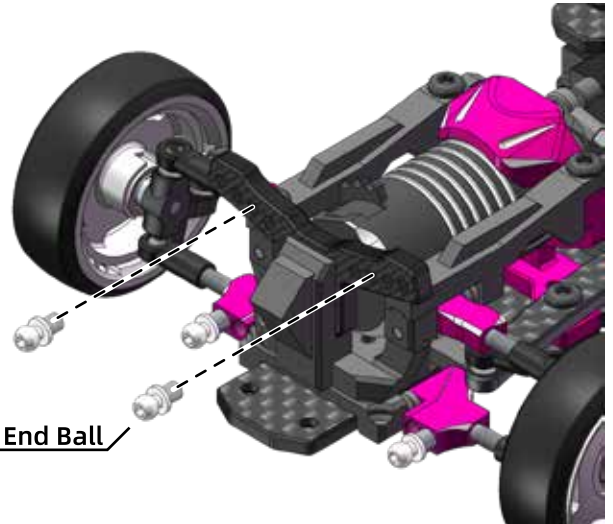

2.75 Rod End Ball



Short Body

Adjusting Nut

Hard Spring

Short Shock

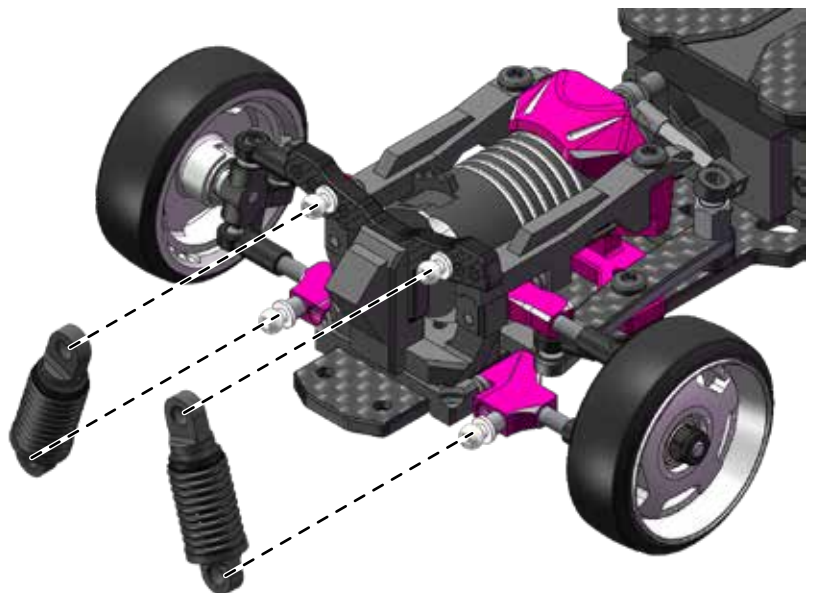



M1.6*2 Set Screw x 2



M2*6 CS Screw x 4

M1.6*2 Set Screw

M2*6 CS Screw

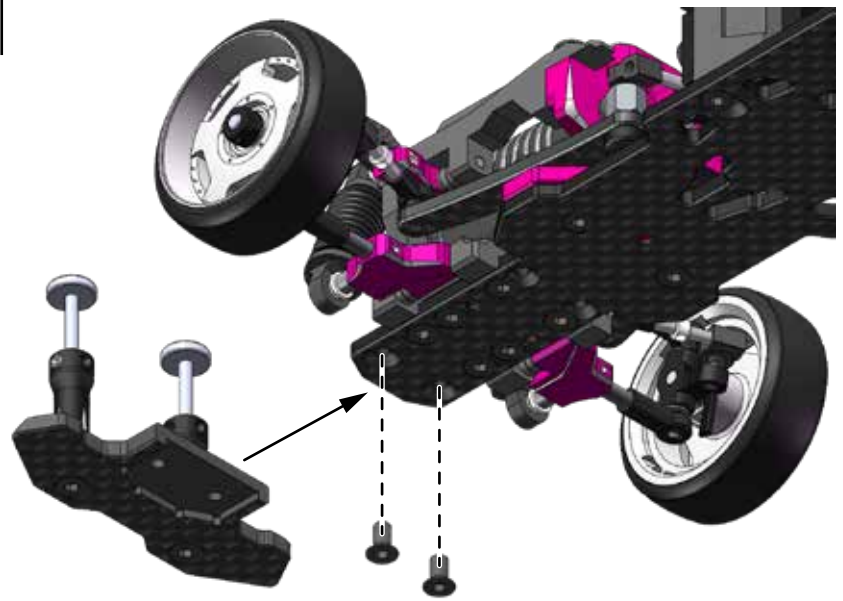

M2*6 CS Screw



2*3.2*1 Spacer x 2



M2*4 CS Screw x 6



Jam Nut x 2



M2*10 CS Screw x 2

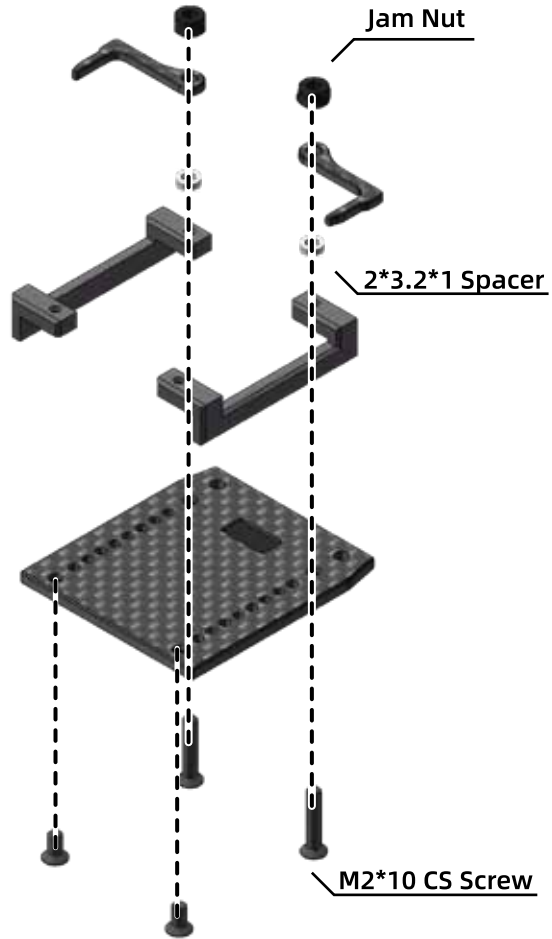

M2*4 CS Screw

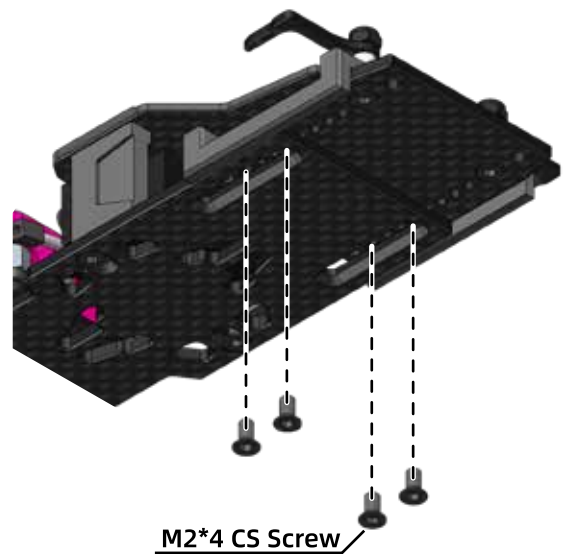
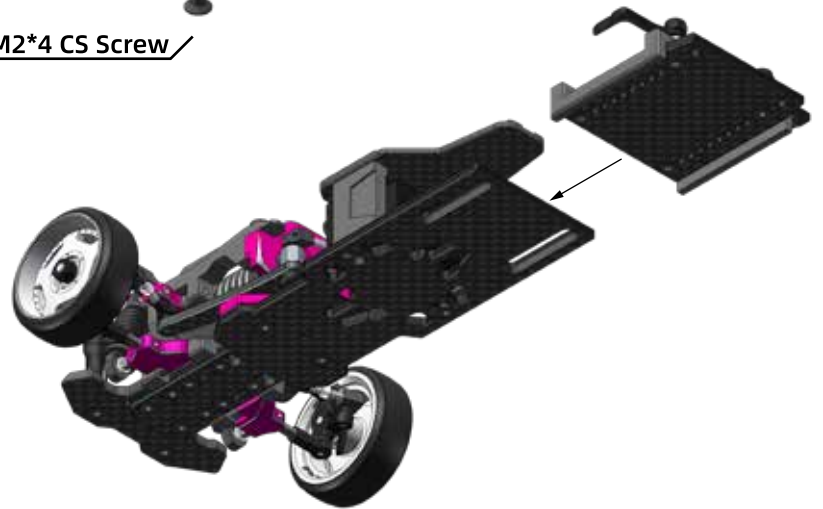

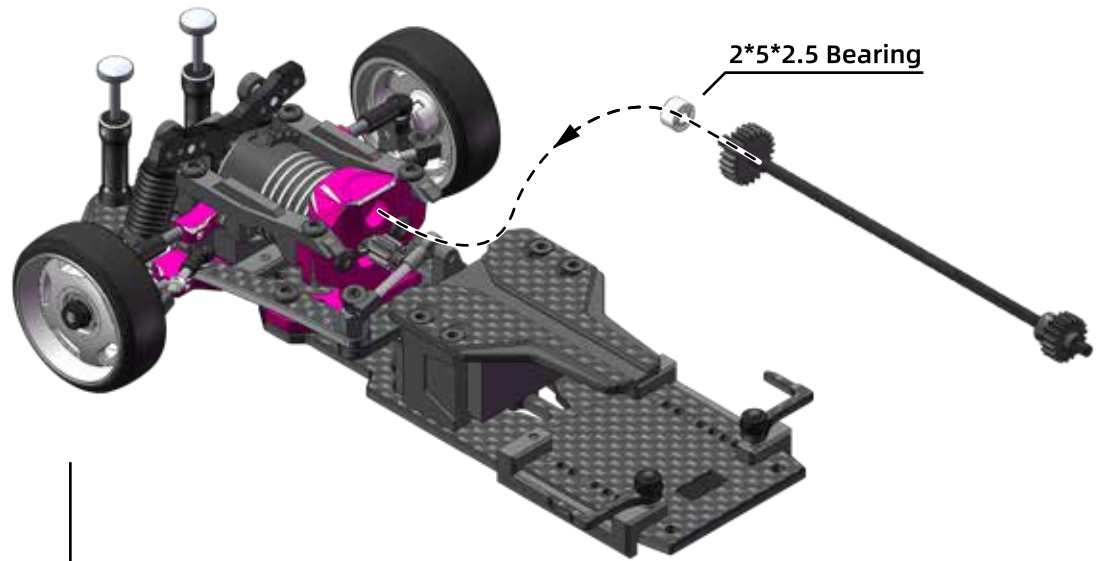

2*5*2.5 Bearing x 1

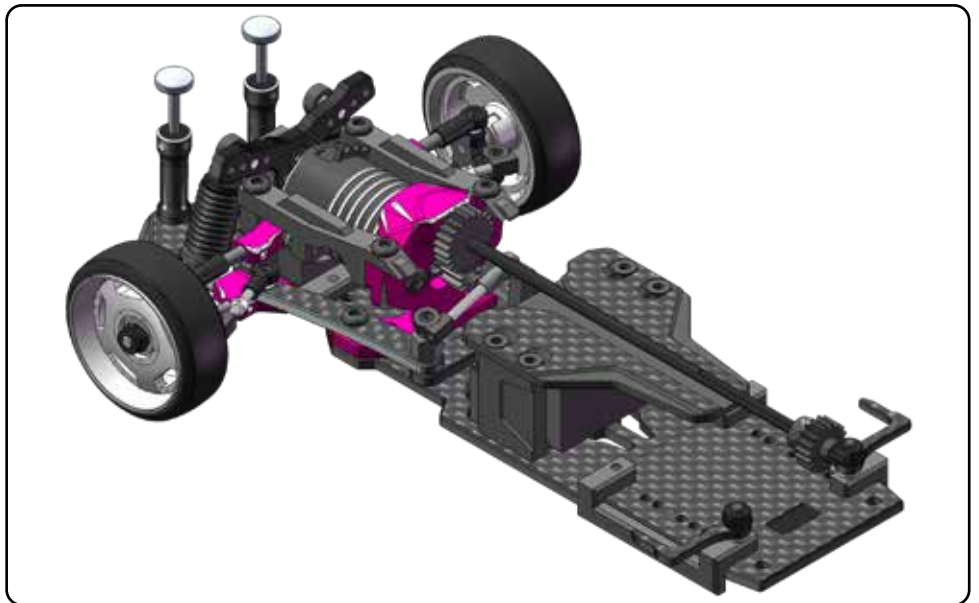

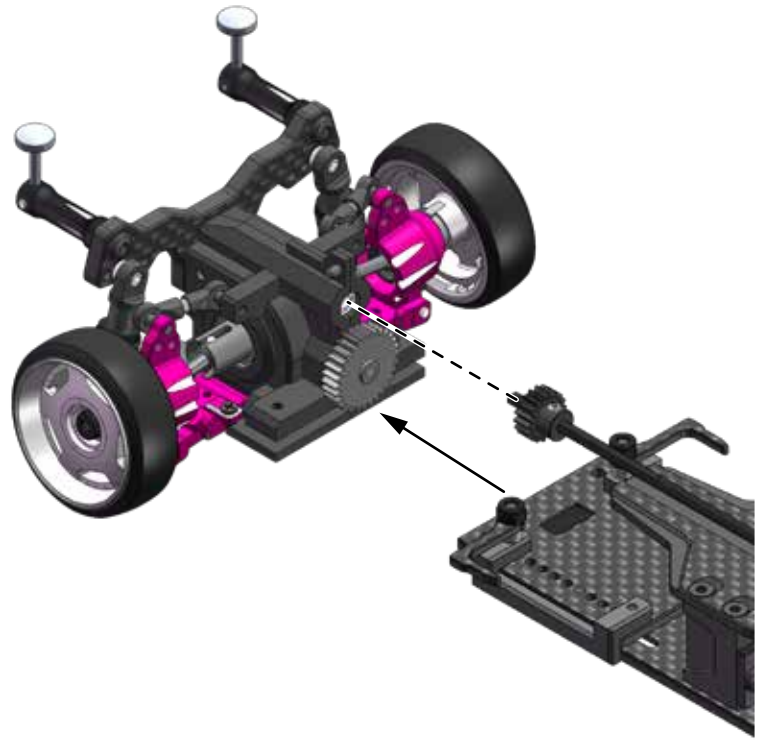

M2*6 CS Screw x 2

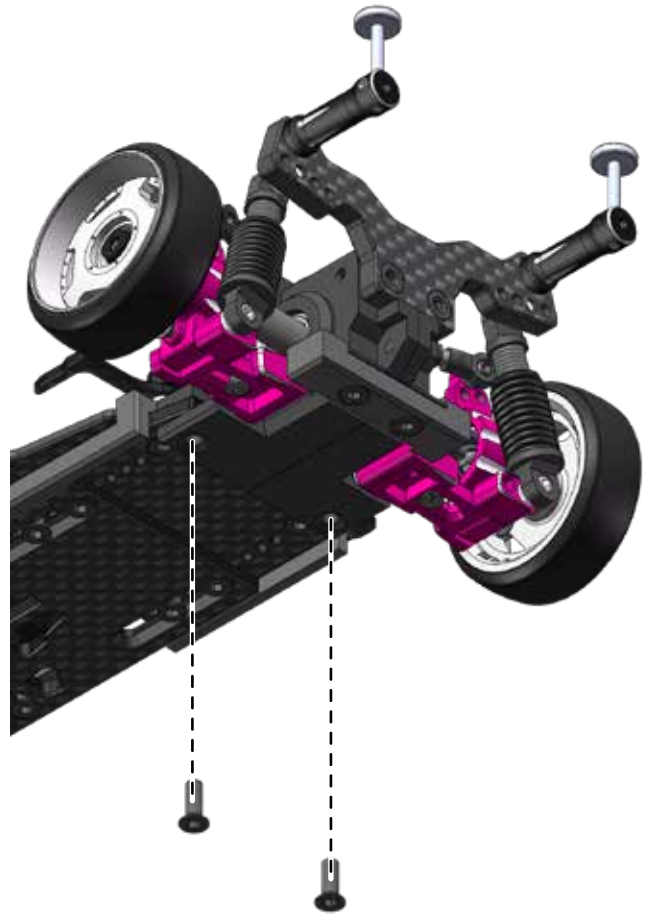

M2*6 CS Screw

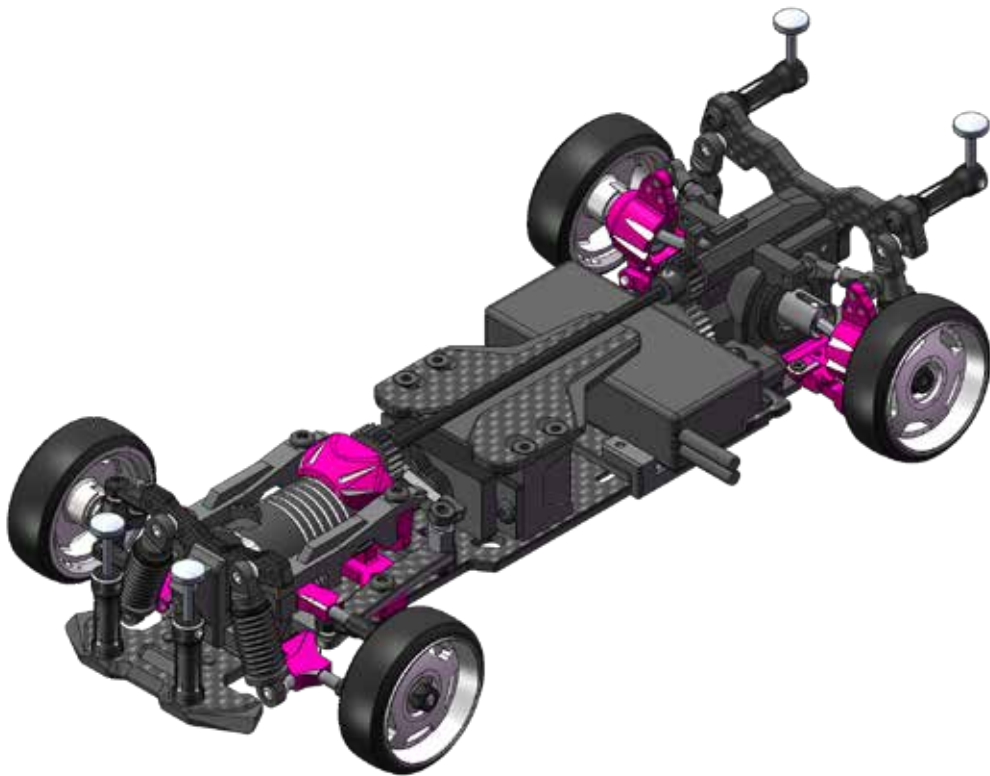
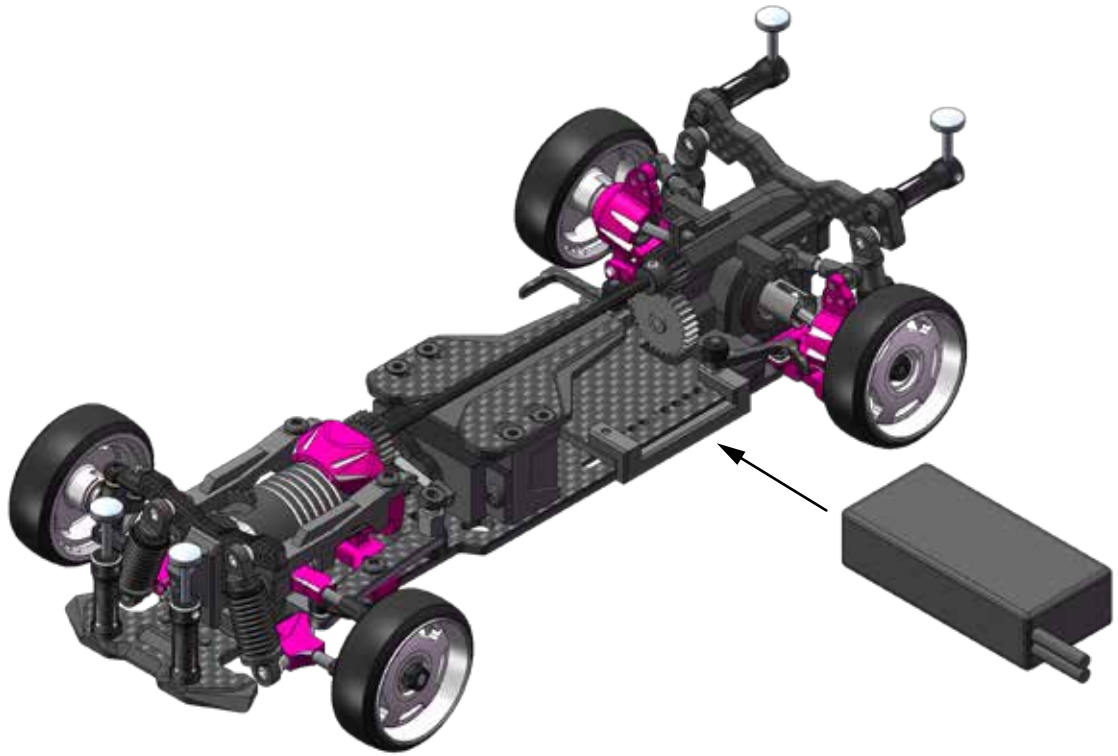

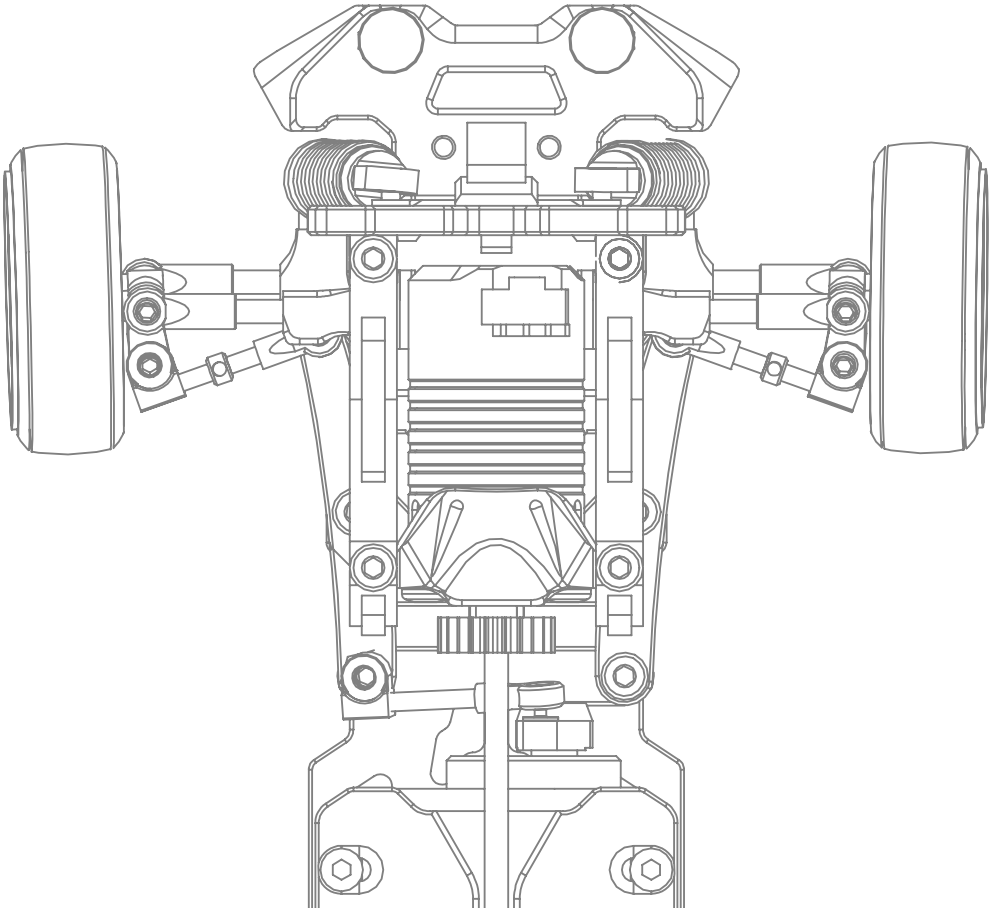

BMHOLLY

